

# Sankosha – New Techniques Complimenting Design Options *Your Machines for Contemporary Shirts*



**LP-560**  
Single-buck Shirt Press



**LP-660**  
Single Collar/Cuff Press

## ■ Affordable World Standard

Top quality finish of shirts with affordability

## ■ Hybrid Finishing System

Shirt body will be finished by press head in front and hot air in rear (Press option available)

## ■ Slim Sized Body

Excellent finish for slim shirts with new fabric cover design (heat/shrink/stretch resistant)

## ■ Large Yoke Press

Newly developed press surface for optimum result

## ■ User-Friendly Operations

Ease of use, yet quality finish with further options available

<http://www.sankosha-mfg.com>

Visit our web site for valuable Information  
for your business expansion.



SANKOSHA MANUFACTURING CO., LTD.  
988 Kanoya, Hachioji, Tokyo 193-0815, Japan  
Tel: +81 42 621 1182 Fax: +81 42 620 0751

# LP560 / LP660 Valued Features

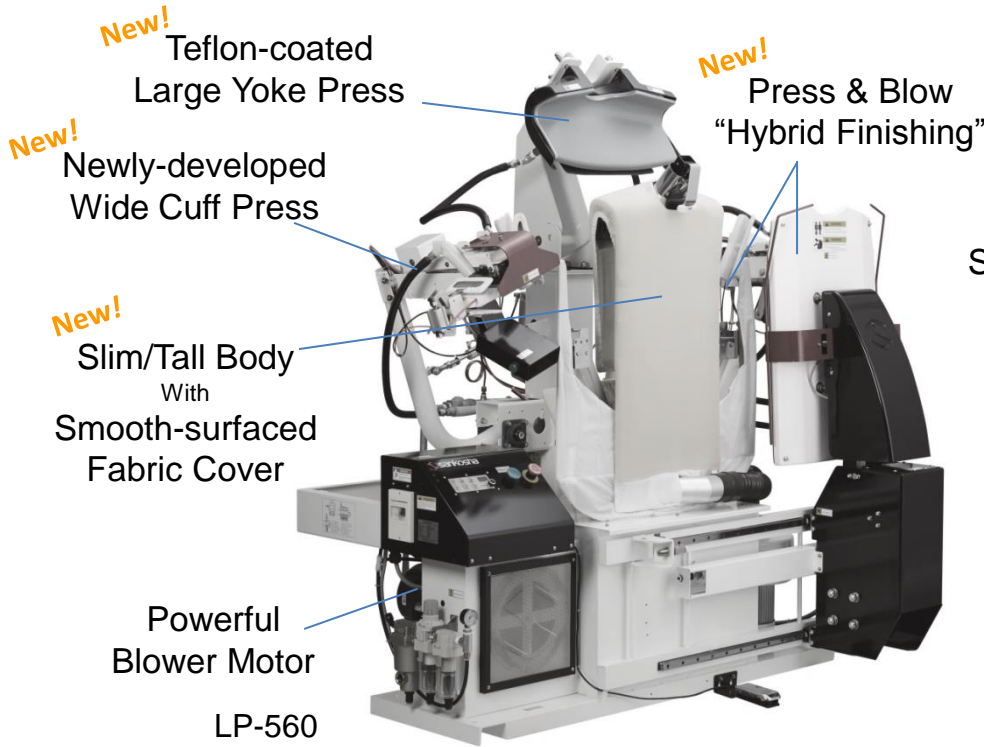

**New!** Press & Blow "Hybrid Finishing"

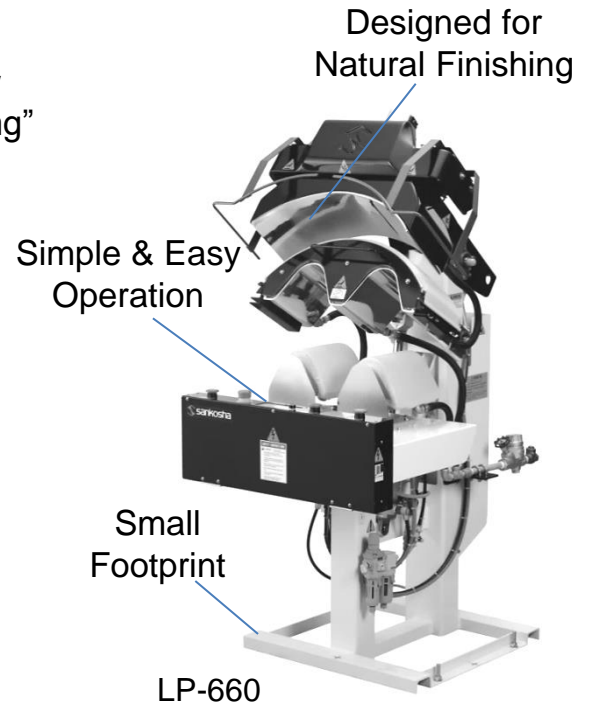

## Highest Quality Safety Ratings

### Specifications

| Model                        |                   | LP-560E              | LP-660E-V2        |
|------------------------------|-------------------|----------------------|-------------------|
| Power Requirement            |                   | 3 phase 400V 50Hz    | Single phase 230V |
| Power Consumption            |                   | 1.6 kW               | 0.03 kW           |
| Air                          | Air Pressure      | 0.6 MPa              | 0.6 MPa           |
|                              | Air Consumption   | 43.2 litre / cycle   | 18 litre / cycle  |
|                              | Air Pipe          | 3/8"                 | 3/8"              |
| Steam                        | Steam Pressure    | 0.6 MPa              | 0.6 MPa           |
|                              | Steam Consumption | 45 kg / h            | 10 kg / h         |
|                              | Steam Pipe        | In 3/4", Out 1/2" x3 | 1/2"              |
| Net Weight                   |                   | 475 kg               | 200 kg            |
| Dimensions W x D x H (mm)    |                   | 1920 x 1170 x 1890   | 730 x 1000 x 1620 |
| Installation Dimensions (mm) |                   |                      |                   |

Features and specifications are subject to change without notice.

### Body Buck Size Comparison

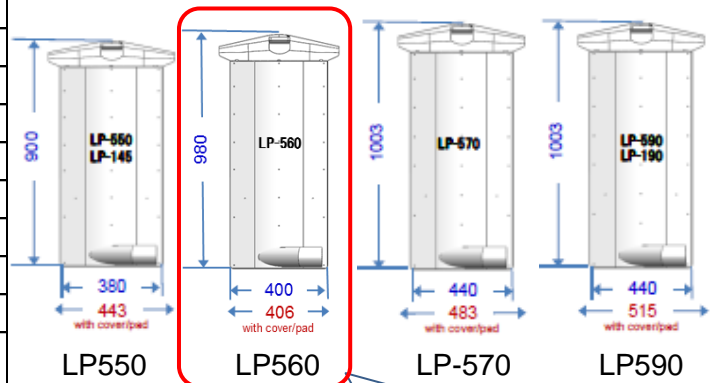

Good for slim-fit shirts

### Option



#### Dual Temperature System

For reducing temperature of press heads to minimize Shrinkage keeping hot air temperature high..

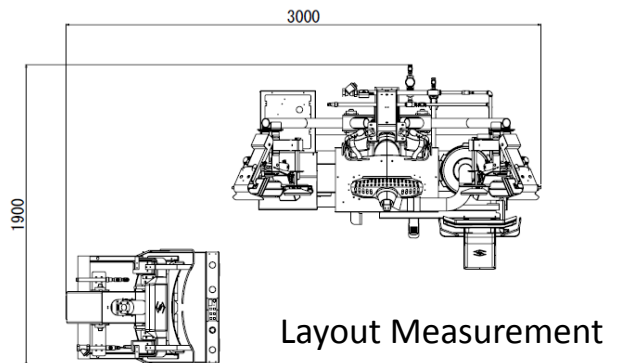

Distributed by: